

**Parts List**

<u>Qty</u>	<u>Reference</u>	<u>Description</u>
1	A	Floor Support Frame
1	B	Zinc Plated Center Shaft
1	C	Cable Eyelet
1	D	Center Frame
4	E	Extension Arm
1	F	Stud Support Frame
1	G	Hardware Kit (bag)

**Safety Rules**

This product was designed for certain applications only. Elecor strongly recommends that this product not be modified and/or used for any purpose other than that for which it was designed.



**CAUTION**

Use care when lifting the Cable Dispenser. Unload coils of armored cable or NM-B first.

**Capacity**

Minimum inside coil diameter 5 1/2"  
 Maximum outside coil diameter 17"  
 Maximum weight 50 lbs

**Tools Required for Assembly**

None

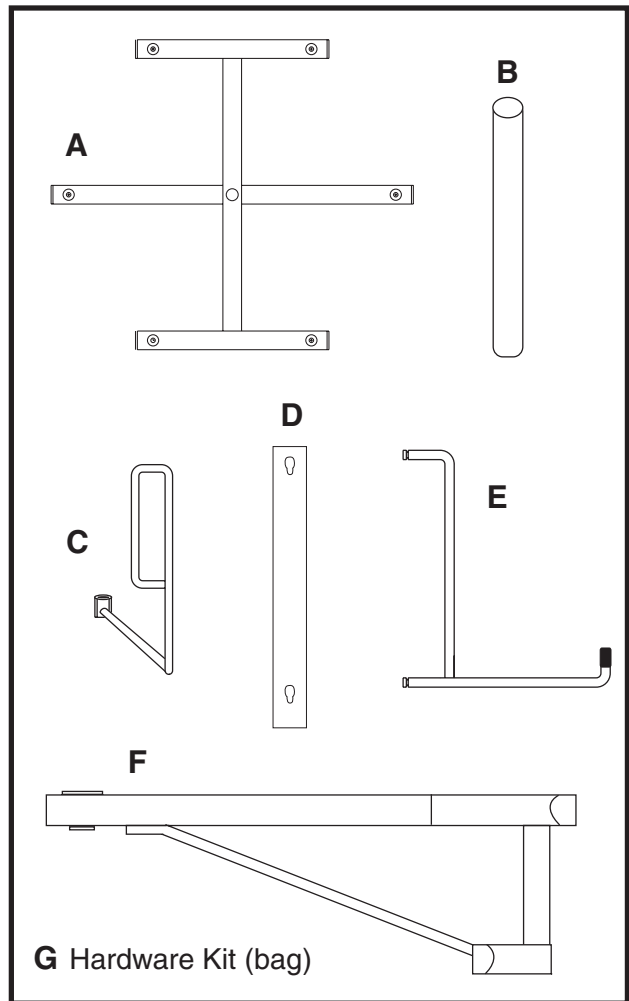

**One Year Limited Warranty**

Elecor will repair or replace, at its expense and at its option, any Elecor product or accessory which in normal use has proven to be defective in workmanship or material, provided that the customer notifies his supplying distributor of the alleged defect within one year from the date of delivery. If requested by Elecor customer must provide reasonable opportunity to verify the defect by inspection. Elecor will not be responsible for any asserted defect which has resulted from misuse, abuse, repair or alteration. Under no circumstances will Elecor be liable for incidental or consequential damages resulting from defective products. This warranty is Elecor's sole warranty and sets forth the customer's exclusive remedy with respect to defective products; all other warranties, expressed or implied, whether of merchantability, fitness for purpose, or otherwise, are expressly disclaimed by Elecor.

**Parts Or Warranty Assistance**

All Elecor products and accessories are manufactured to high quality standards. To obtain additional information regarding your Elecor product or to obtain parts, accessories or warranty assistance, please contact customer service at 1-888-466-8600 x 106.

**ELECOR LLC**

13 Wood Street  
 P.O. Box 26125  
 West Haven, CT 06516  
 Phone: 203-937-3029  
 Fax: 203-937-3028

For Parts, Accessories, or  
 Warranty Assistance, Please  
 Call 1-888-466-8600 x 106



**Manufacturers of Quality  
 Electrical Products**

**MH8110 Cable Dispenser**

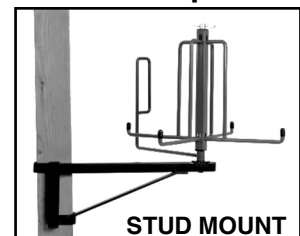

**Instruction Manual**

## Hardware

The hardware for assembling the Cable Dispenser is enclosed in the MH8110-G Hardware Kit (bag). The kit contains the items shown at right.

## Assembly Instructions

**1** Insert Extension Arm (E) [Figure 1] into the Center Frame. Line up the grooves in the end of the Extension Arm with the holes in the Center Frame (D) and push down until grooves slide to the bottom of the keyway. Repeat the process for the other three Extension Arms.

**2** Insert the Center Frame Cap (2) [Figure 2] into the top of the Center Frame. Make certain the tabs on each side snap into the holes in the Center Frame (D). Insert the Center Frame Cap (3) [Figure 2] into the bottom of the Center Frame (D). With the Frame Caps in place, the Extension Arms will be locked into the keyways in the Center Frame.

**3** Choose the Floor Support Frame (A) or Stud Support Frame (F) [Figure 3] and thread the Zinc Plated Center Shaft (B) into the hole in the Support Frame as shown in Figure 3.

**Note:** Floor Support Frame (A) can be interchanged with Stud Support Frame (F) easily for different uses.

**4** Slide the Cable Eyelet (C) [Figure 4] over the Zinc Plated Center Shaft (B).

**5** Slide the Extension Arm assembly [Figure 4] over the Zinc Plated Center Shaft (B).

**6** Insert the Hitch Pin Clip (1) [Figure 4] into the hole at the top of the Zinc Plated Center Shaft (B).

## Operating Instructions

**Floor Support Frame:** Load a coil of armored cable or NM-B over the Extension Arm assembly and thread the end of the cable through the Cable Eyelet (C).

OR

**Stud Support Frame:** Mount Stud Support Frame (F) on 2" x 4" wood stud [Figure 5]. Ensure wood stud is secure. No fasteners are required to secure Support Frame to stud. Load a coil of armored cable or NM-B over the Extension Arm assembly and thread the end of the cable through the Cable Eyelet (C).

**CAUTION:** Use care when lifting the Cable Dispenser. Unload coils of armored cable or NM-B first. Pulling cable from dispenser too fast may result in tangles and/or backlash.

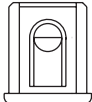
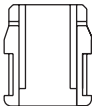
Reference	Description	Qty
1	 3 X 65 HITCH PIN CLIP	1
2	 CENTER FRAME CAP (2)	1
3	 CENTER FRAME CAP (3)	1

**HARDWARE KIT**

